

# YASKAWA

# MOTOMAN MH50-20 II

Handling & General Applications  
with the MH-series



The MOTOMAN MH50-20 II is a dynamic, high-speed robot featuring an extended reach for large parts. It offers superior performance in arc welding, coating, gluing, dispensing, material cutting and material handling applications.

#### KEY BENEFITS

- High repeatability  $\pm 0.15$  mm
- Ideal for a variety of applications, multi-purpose robot
- Very wide motion range
- Small interference radius reduces floorspace requirements
- Specifically designed for processing large parts

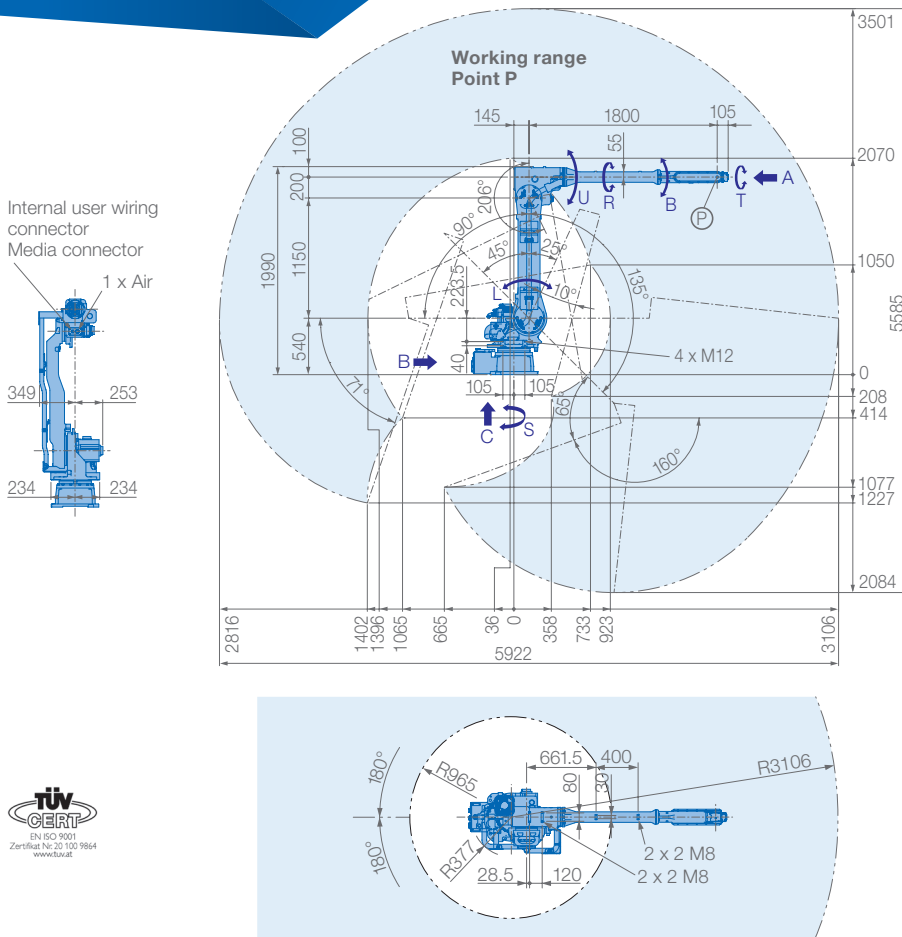

## View A

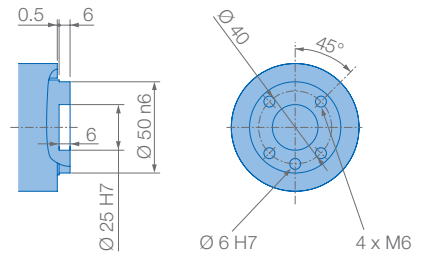

## View B

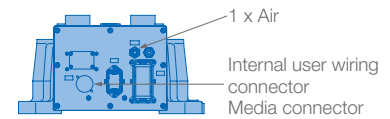

## View C

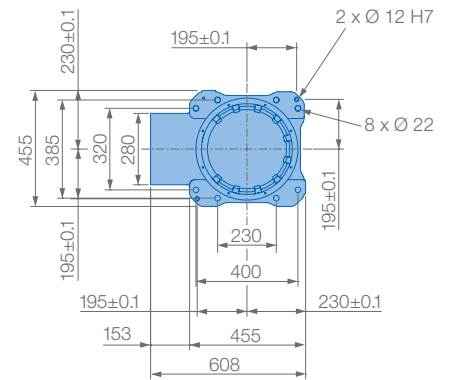

Mounting options: Floor, ceiling, wall  
Protection class: IP54/67

## Allowable wrist load

**Please note wall mounting option:**  
±30° S-axis limit

**Please note ceiling mounting option:**  
Please notice working range of B-axis

**Please note tilted robot:**  
0°–90° limitation of S-axis, details on request

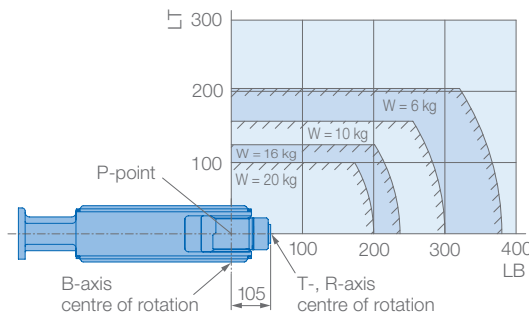

<b>Wrist + U-arm in front</b>	Up to 20 kg for attaching load mass including wrist load
<b>U-arm behind</b>	Up to 10 kg, 49 N · m (5 kgf · m) max. for increased moment amount of upper arm (floor-, ceiling-mounted type only)
<b>S-axis below</b>	Up to 30 kg (floor-, ceiling-mounted type only)

Specifications MH50-20 II						
Axes	Maximum motion range [°]	Maximum speed [°/sec.]	Allowable moment [Nm]	Allowable moment of inertia [kg · m <sup>2</sup> ]	Controlled axes	6
<b>S</b>	±180	180	–	–	<b>Max. payload [kg]</b>	20
<b>L</b>	+135/–90	178	–	–	<b>Repeatability [mm]</b>	±0.15
<b>U</b>	+251/–160	178	–	–	<b>Max. working range R [mm]</b>	3106
<b>R</b>	±190	400	39.2	1.05	<b>Temperature [°C]</b>	0 to +45
<b>B</b>	+230/–50	400	39.2	1.05	<b>Humidity [%]</b>	20 – 80
<b>T</b>	±360	600	19.6	0.75	<b>Weight [kg]</b>	495
					<b>Power supply, average [KVA]</b>	3.5

## YASKAWA Europe GmbH

Robotics Division  
Yaskawastraße 1  
85391 Allershausen  
Germany

Tel. +49 (0) 8166 90-0  
robotics@yaskawa.eu.com  
www.yaskawa.eu.com

YR-MH00050-J10  
A-07-2018, A-No. 167073