

YASKAWA

MOTOMAN MH80 II

Handling & General Applications
with the MH-series



The MOTOMAN MH80 II is a versatile high speed 6-axis robot, providing a high payload of up to 80 kg. It offers superior performance in material handling, machine tending, processing and dispensing applications.

Despite its streamlined body, the MOTOMAN MH80 II features a wide work envelope with a small interference radius. Thereby it can be placed close to machines for loading and unloading of parts, which reduces the required floor space to a minimum.

KEY BENEFITS

- Flexible and powerful (payload of 80 kg)
- High axis speeds
- Improved wrist ratings provide higher handling capacity
- Small interference radius reduces floor space requirements

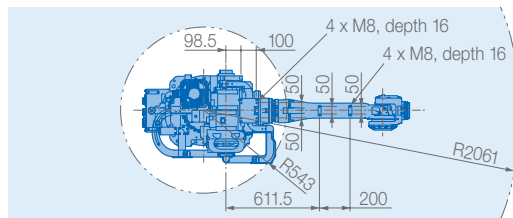
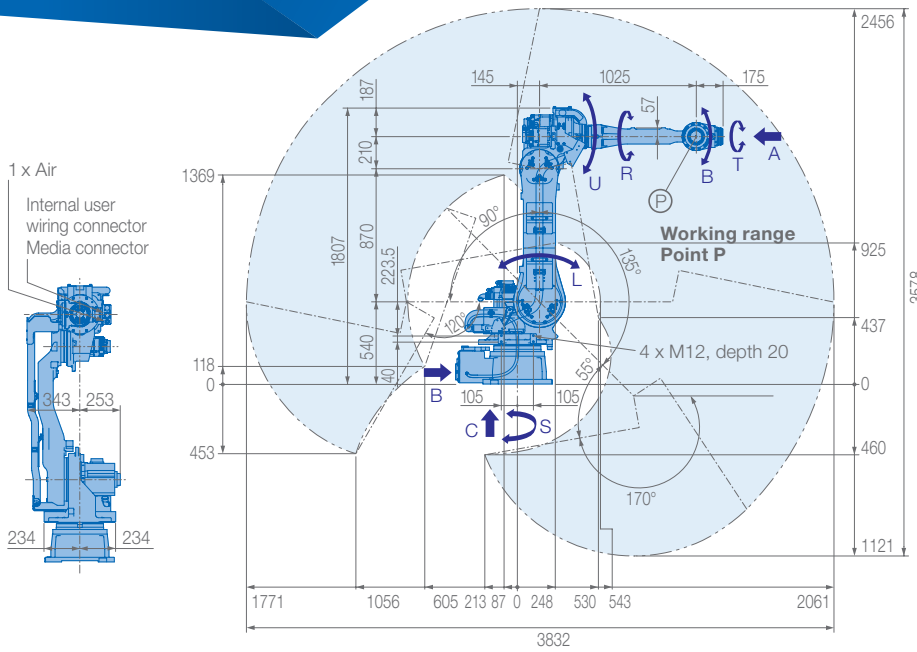

Allowable wrist load

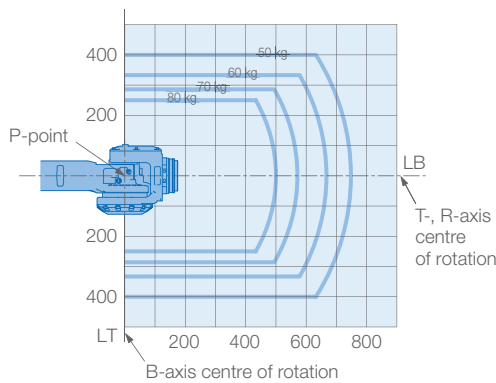

View A

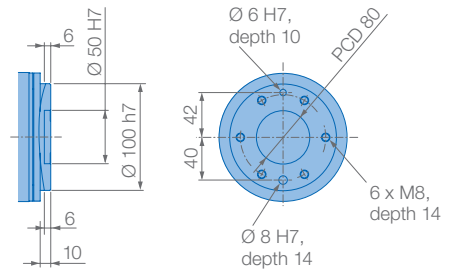

View B

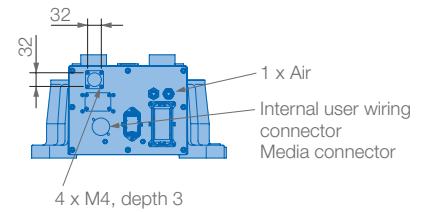

View C

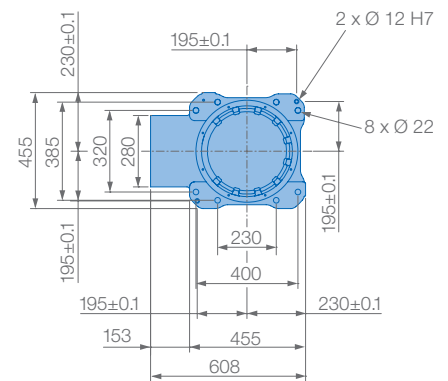

Mounting options: Floor, ceiling, wal
 Protection class: IP54/67
Please notice: Just valid for body/wrist, connector base not protected



Specifications MH80 II						
Axes	Maximum motion range [°]	Maximum speed [°/sec.]	Allowable moment [Nm]	Allowable moment of inertia [kg · m ²]	Controlled axes	6
S	±180	170	-	-	Max. payload [kg]	80
L	+135/-90	140	-	-	Repeatability [mm]	±0.07
U	+251/-170	160	-	-	Max. working range R [mm]	2061
R	±360	230	392	28	Temperature [°C]	0 to +45
B	±125	230	392	28	Humidity [%]	20 - 80
T	±360	350	196	11	Weight [kg]	555
					Power supply, average [KVA]	4.5

YASKAWA Europe GmbH

Robotics Division
 Yaskawastraße 1
 85391 Allershausen
 Germany

Tel. +49 (0) 8166 90-0
 robotics@yaskawa.eu.com
 www.yaskawa.eu.com

YR-MH00080II-J00
 B-12-2018, A-No. 167105