

# HTC-500D, -1000D

Head- and tailstock positioner with horizontal rotation.

One station positioner for workpieces requiring rotation about one axis. Head- and tailstock with MotoMount fixture mounting system mounted on a bed. The distance between headstock and tailstock is fixed.

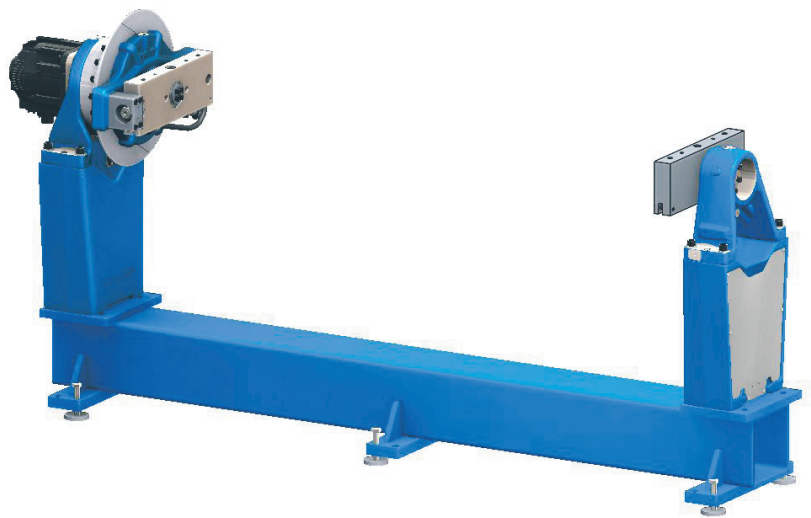

| Technical data                        |                  | HTC-500D          |                   | HTC-1000D         |                   |
|---------------------------------------|------------------|-------------------|-------------------|-------------------|-------------------|
| <b>Max. capacity</b>                  | load             | <b>500 kg</b>     |                   | <b>1000 kg</b>    |                   |
|                                       | offset           | 150 mm            |                   | 150 mm            |                   |
| <b>Motor power</b>                    |                  | 1.3 kW            |                   | 3.0 kW            |                   |
| <b>Gear ratio</b>                     | reducer          | 165:1             |                   | 170:1             |                   |
| <b>Speed</b>                          | nominal          | 9.0 rpm           |                   | 8.8 rpm           |                   |
|                                       | maximum          | 23 rpm            |                   | 23 rpm            |                   |
| <b>Torque</b>                         | rated            | 1177 Nm           |                   | 2689 Nm           |                   |
|                                       | continuous rated | 941 Nm            |                   | 2151 Nm           |                   |
|                                       | peak             | 2354 Nm           |                   | 5378 Nm           |                   |
| <b>Rated welding current Standard</b> | 100%             | 350 A             |                   | 350 A             |                   |
|                                       | 60%              | 460 A             |                   | 460 A             |                   |
| <b>Rated welding current Option</b>   | 100%             | 860 A             |                   | 860 A             |                   |
|                                       | 60%              | 1120 A            |                   | 1120 A            |                   |
|                                       | 35%              | 1380 A            |                   | 1380 A            |                   |
| <b>Max fixture width</b>              | diameter         | 1250              | 1650              | 1250              | 1650              |
| <b>Part No.</b>                       |                  | <b>141510-xxx</b> | <b>141512-xxx</b> | <b>141514-xxx</b> | <b>141516-xxx</b> |

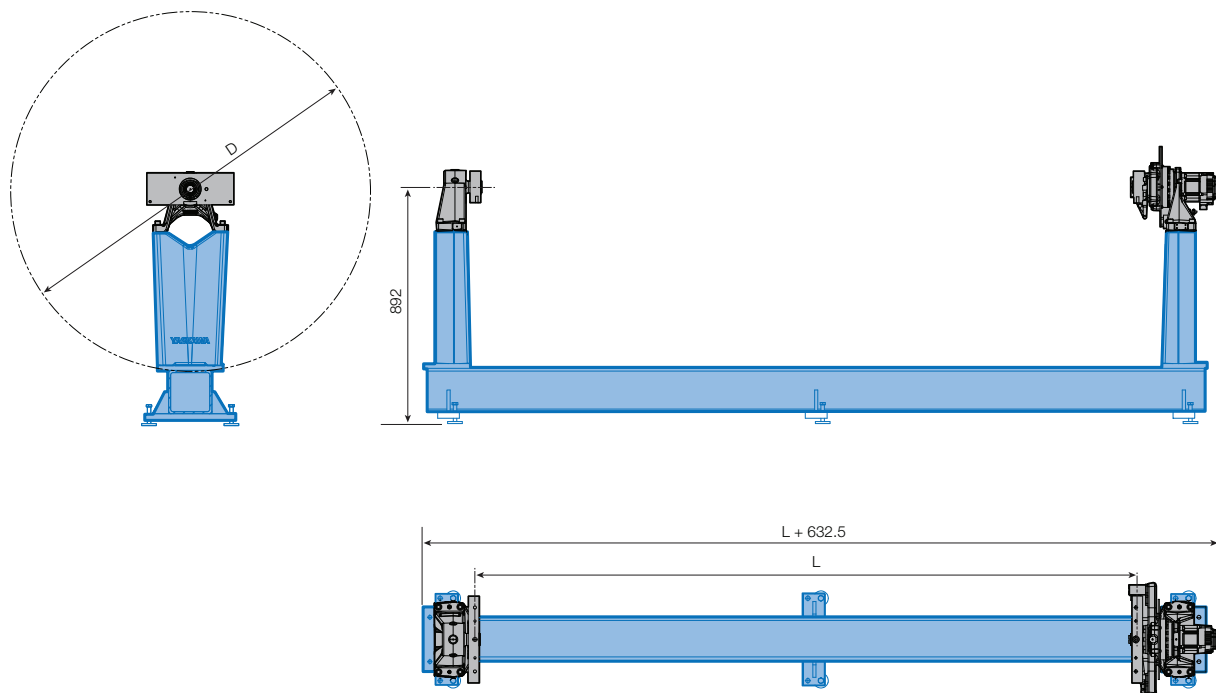

| Type                            | L    | D    | Part No.   |
|---------------------------------|------|------|------------|
| <b>HTC-500D</b>                 | 2050 | 1250 | 141510-101 |
|                                 |      | 1650 | 141512-101 |
|                                 | 3050 | 1250 | 141510-104 |
|                                 |      | 1650 | 141512-104 |
|                                 | 4050 | 1250 | 141510-106 |
|                                 |      | 1650 | 141512-106 |
| <i>Other lengths on demand.</i> |      |      |            |
| <b>HTC-1000D</b>                | 2050 | 1250 | 141514-101 |
|                                 |      | 1650 | 141516-101 |
|                                 | 3050 | 1250 | 141514-104 |
|                                 |      | 1650 | 141516-104 |
|                                 | 4050 | 1250 | 141514-106 |
|                                 |      | 1650 | 141516-106 |
| <i>Other lengths on demand.</i> |      |      |            |