

# Weld4Me robot

Collaborative Robotics for  
easy Welding of small Series



As an alternative or supplement to manual MIG/MAG welding with air-cooled welding equipment, the Weld4Me robot station offers all the advantages needed. It has a small footprint and is easy to move with a hand pallet truck, and it brings the consistent quality of robotic welding to your production processes.

The hybrid robot mounted on top combines the strength and accuracy of the industrial robot with the safety features necessary for human-robot collaboration. Besides, the IP67 protection class provides superior capabilities for applications in rough welding environments. Due to direct teaching and the customized welding wizard software, operating and programming the Weld4Me robots is easy to learn for welding personnel, even without prior robotics knowledge.

## KEY BENEFITS

- Easy to integrate due to small footprint and high IP67 protection class
- Easy to install and operate
- Easy to relocate and start up again
- Easy to program with the welding wizard

## SCOPE OF DELIVERY (Weld4Me base package)

- MOTOMAN HC10DT IP67 robot with YRC1000 controller
- EC declaration of incorporation of partly completed machinery, according to machinery Directive 2006/42/EC, Annex II.1.B.
- Movable robot stand
- Teach box fixture
- Welding Wizard for easy robot job creation
- Calibration kit for welding torch



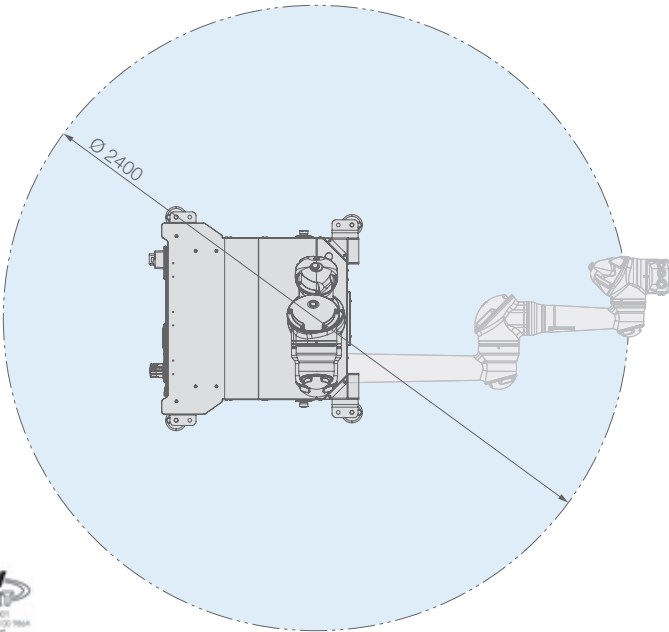
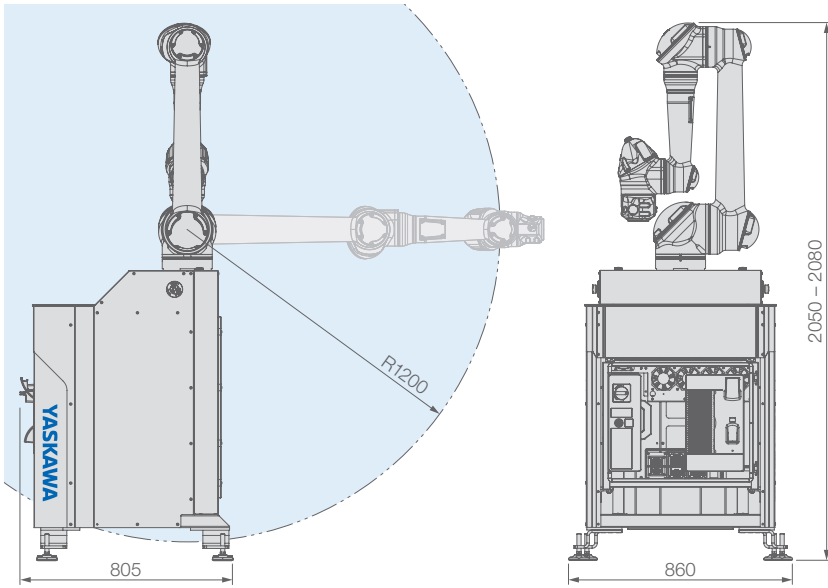

## Human-robot safety features

The robot monitors and limits its speed and range, in one or more zones, with the Functional Safety Unit (FSU). In addition to this, the Power and Force Limiting (PFL) function will stop the robot as soon as the detected external force exceeds a threshold value.

**Always make sure that Weld4Me is set to collaborative mode during operation.**

## OPTIONS

- Complete EWM and Fronius welding packages (power source, welding torch and cable package)
- Welding table 1200 x 800mm, fixture clamps and glare shield
- Calibration kit with cups and wire cutter
- Clamps for mounting the calibration kit onto the table
- Trolley for welding power source
- Base kit for welding equipment from other suppliers on request
- Robot jacket and wrist cover for heavy spatter applications
- Other colours by customer choice
- Further accessories

Technical data Weld4Me robot	
Dimensions	860 (W) x 2080 (H) x 805 (D)
Collaborative robot	MOTOMAN HC10DT IP67
Safety standard	ISO 10218-1 (5.10.5 Power and Force limiting)
Controller	YRC1000
Safety function	ISO 13849-1, PLd, Cat. 3
Weight	236 kg (including robot and control cabinet)

## Robotic Automation p/l

14/4 Avenue of Americas  
Newington, NSW 2127  
Australia

Tel. 1300 552 333  
webenquiry@ragroup.com.au  
www.ragroup.com.au